



INNOVATIVE DISPLAY TECHNOLOGIES

17171 MURPHY AVENUE

IRVINE, CALIFORNIA 92614-5915

P: 949-417-8070/F: 949-417-8075

E-mail: [info@shellyinc.com](mailto:info@shellyinc.com)

Website: [www.shellyinc.com](http://www.shellyinc.com)

## Specification

**Part Number : SOG32034031-BTV-BWLW**

**Customer :**

<b>APPROVED BY:</b> ( FOR CUSTOMER USE ONLY )	<b>PCB VERSION:</b>	<b>DATE:</b>
--	---------------------	--------------

SOLD BY	APPROVED BY	CHECKED BY	ISSUE DATE

MODLE NO :

**RECORDS OF REVISION**

DOC. FIRST ISSUE

VERSION	DATE	REVISED PAGE NO.	<b>SUMMARY</b>
0	2008.04.21		First issue
A	2008.05.20	18	Modify backlight information
B	2008/11/3	18	Modify backlight information

# Contents

1. Module Classification Information
2. Precautions in use of LCD Modules
3. General Specification
4. Absolute Maximum Ratings
5. Electrical Characteristics
6. Optical Characteristics
7. Interface Pin Function
8. Contour Drawing & Block Diagram
9. Power supply
10. Timing Characteristics
11. Reliability
12. Backlight Information
13. Inspection specification
14. Material List of Components for RoHs



## **2. Precautions in use of LCD Modules**

- (1) Avoid applying excessive shocks to the module or making any alterations or modifications to it.
- (2) Don't make extra holes on the printed circuit board, modify its shape or change the components of LCD module.
- (3) Don't disassemble the LCM.
- (4) Don't operate it above the absolute maximum rating.
- (5) Don't drop, bend or twist LCM.
- (6) Soldering: only to the I/O terminals.
- (7) Storage: please storage in anti-static electricity container and clean environment.
- (8) The factory reserves the right to change the passive components
- (9). The factory reserves the right to change the PCB Rev.

## **3. General Specification**

<b>Item</b>	<b>Dimension</b>	<b>Unit</b>
Number of Characters	320 x 240 dots	-
Module dimension	160.0x 109.0 x11.5(MAX)	mm
View area	120.0 x 90.0	mm
Active area	115.17 x86.37	mm
Dot size	0.33 x0.33	mm
Dot pitch	0.36 x 0.36	mm
LCD type	FSTN Positive, Transflective (In LCD production, It will occur slightly color difference. We can only guarantee the same color in the same batch.)	
Duty	1/240	
View direction	6 o'clock	
Backlight Type	LED White	

## 4. Absolute Maximum Ratings

Item	Symbol	Min	Typ	Max	Unit
Operating Temperature	$T_{OP}$	-20	-	+70	°C
Storage Temperature	$T_{ST}$	-30	-	+80	°C
Supply voltage for Logic	$V_{DD}$	-0.3	-	7.0	V
Input voltage	$V_I$	-0.3	-	$V_{DD} + 0.3$	V

## 5. Electrical Characteristics

Item	Symbol	Condition	Min	Typ	Max	Unit
Supply Voltage For Logic	$V_{DD}-V_{SS}$	-	4.75	5.0	5.25	V
			3.0	3.3	3.5	
Supply Voltage For LCM	$V_O-V_{SS}$	$T_a=-20^{\circ}\text{C}$	24.6	25.1	25.6	V
		$T_a=25^{\circ}\text{C}$	22.1	22.6	23.1	V
		$T_a=70^{\circ}\text{C}$	19.8	20.3	20.8	V
Input High Volt.	$V_{IH}$	-	$0.8 V_{DD}$	-	$V_{DD}$	V
Input Low Volt.	$V_{IL}$	-	$V_{SS}$	-	$0.2 V_{DD}$	V
Power Supply Current	$I_{DD}$	$V_{DD}=5.0\text{V}$		95	-	mA

\* Note: Please design the VOP adjustment circuit on customer's main board

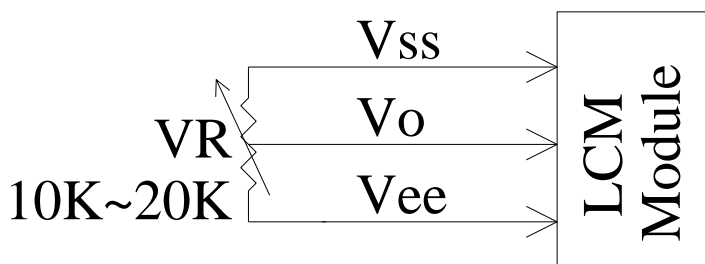

# 6. Optical Characteristics

Ta=25°C

Item	Symbol	Condition	Min	Typ	Max	Unit
View Angle	(V) $\theta$	CR $\geq$ 2	-	35	-	deg
	(H) $\phi$	CR $\geq$ 2	-	30	-	deg
Contrast Ratio	CR	-	2.0	5	-	-
Response Time	T rise	-	-	250	375	ms
	T fall	-	-	200	300	ms

### Definition of Operation Voltage (Vop)

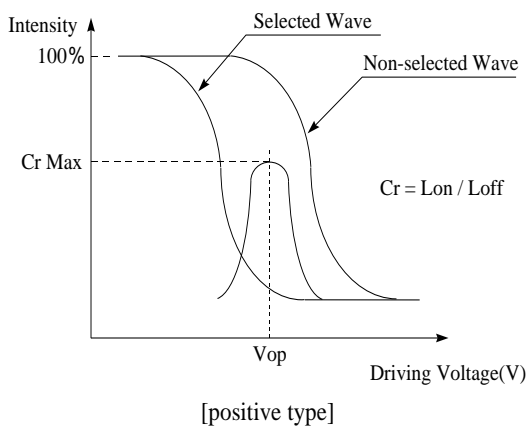

### Definition of Response Time (Tr, Tf)

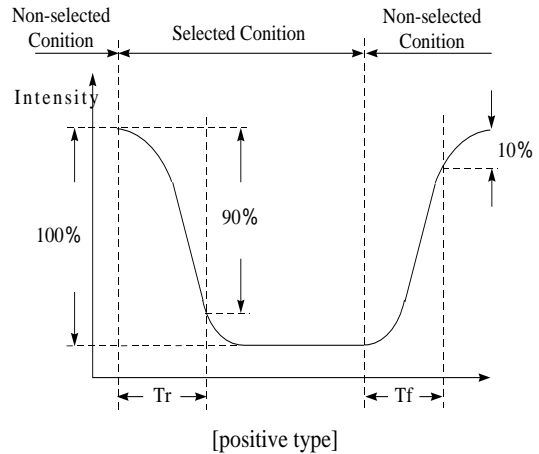

### Conditions:

Operating Voltage: Vop

Viewing Angle ( $\theta$ ,  $\phi$ ): 0°, 0°

Frame Frequency: 64 HZ

Driving Waveform: 1/N duty, 1/a bias

### Definition of viewing angle(CR $\geq$ 2)

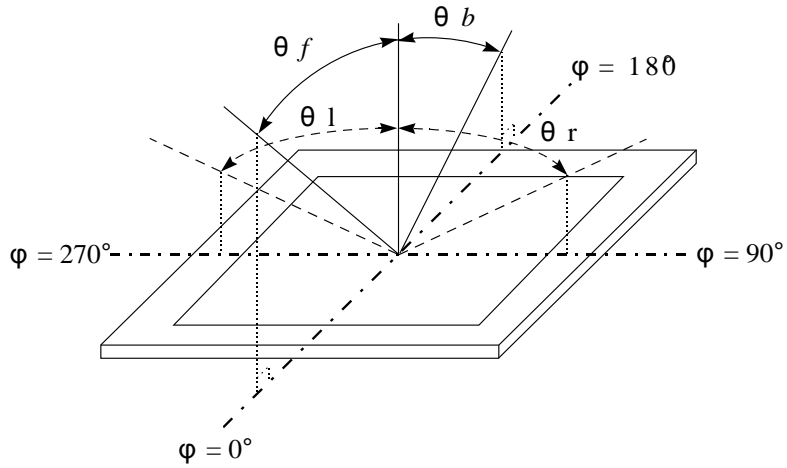

## 7. Interface Pin Function

Pin No.	Symbol	Level	Description
1	D0	H/L	Display data signal
2	D1		
3	D2		
4	D3		
5	/DISPOFF	H/L	H:ON L:OFF
6	FRAME	H	Scan start-up signal
7	NC	-	No connection
8	LOAD	H->L	Input data latch signal
9	CP	H->L	Data input clock signal
10	VDD	-	Power supply for logic (+5V or +3.3V)
11	VSS	-	Signal ground (0V)
12	VEE	-	Power supply for LCD
13	V0	-	LCD contrast adjust voltage
14	NC	-	No connection

### CN2

1	A	-	LED+
2	NC	-	No connection
3	K	-	LED-



# 8. Contour Drawing & Block Diagram

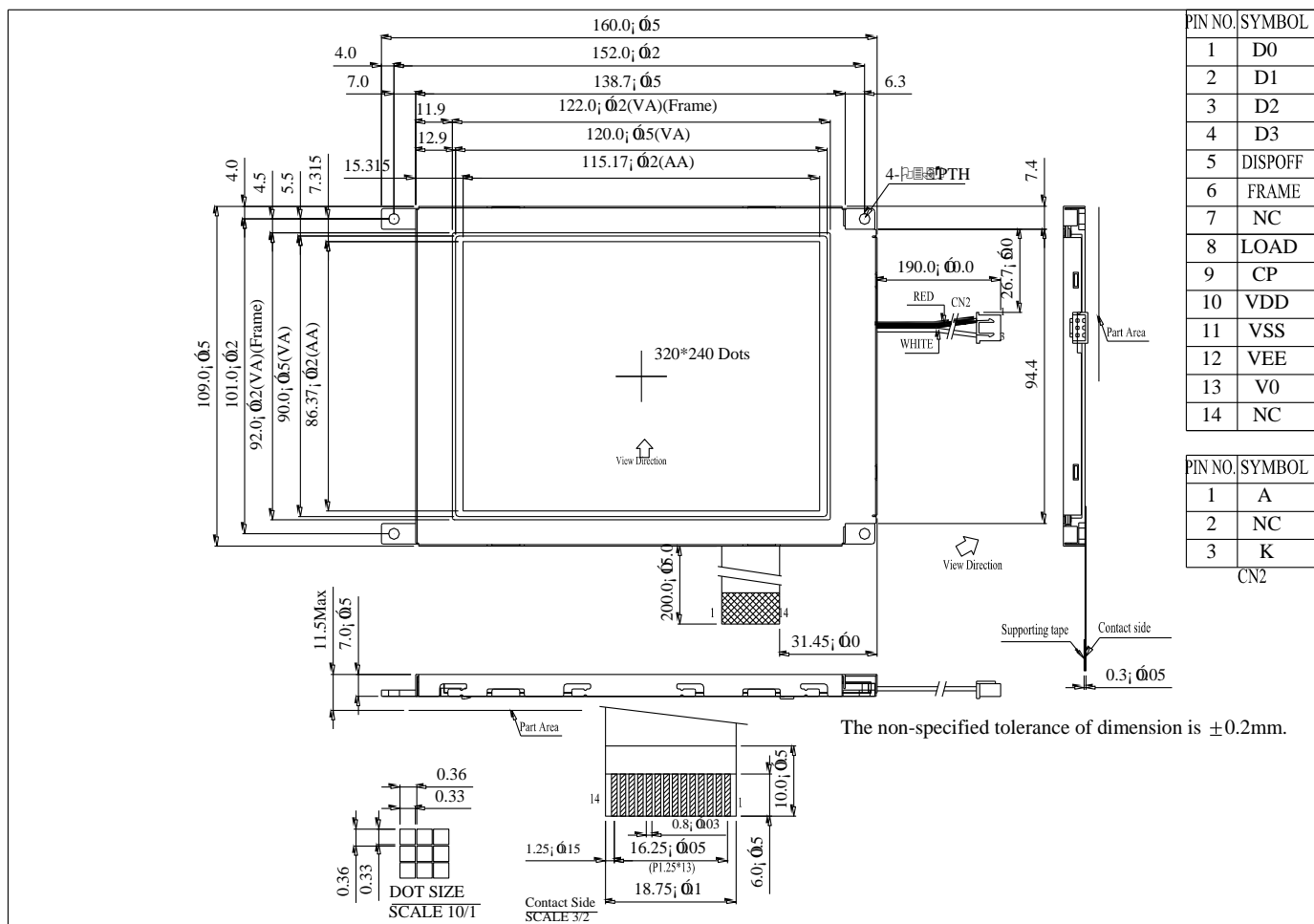

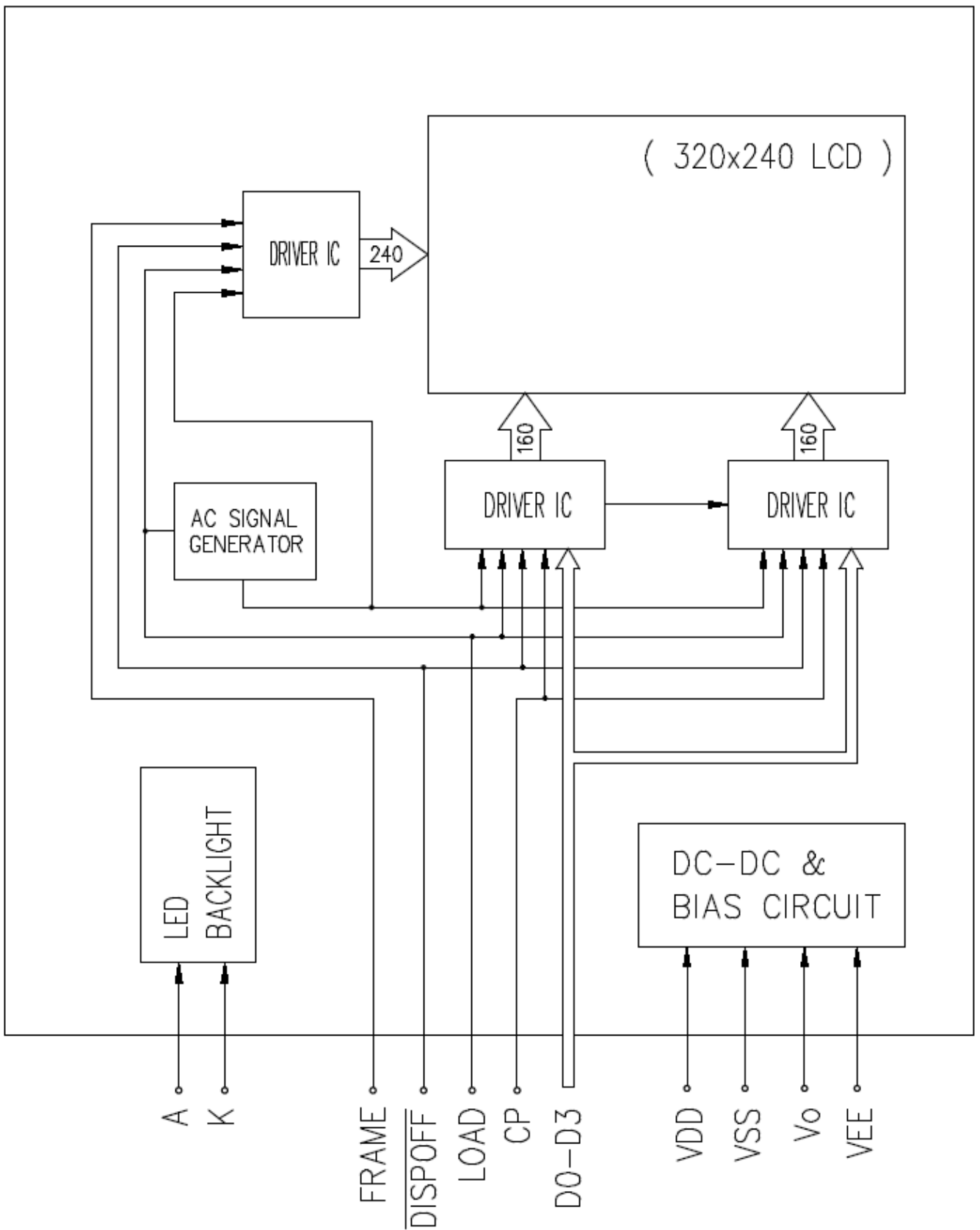

## 9. Power supply

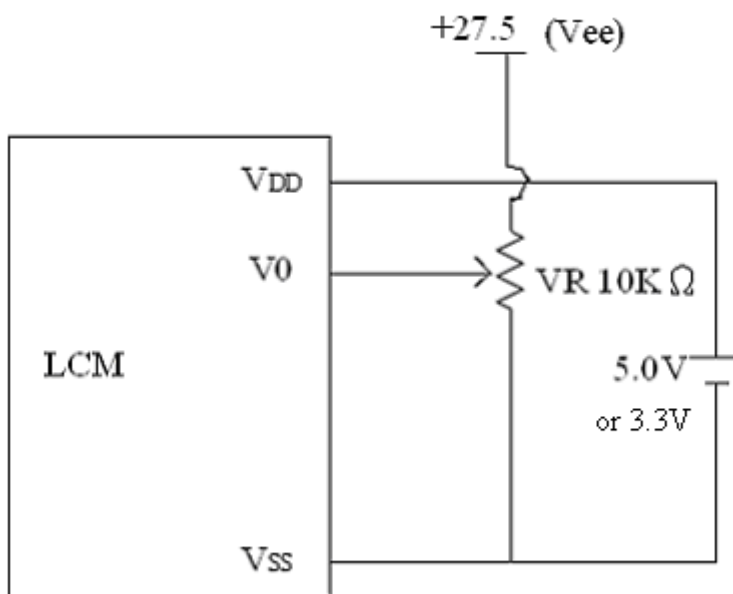

## 10. Timing Characteristics

### 10-1 Clock Characteristics

Ta=-20°C~70°C

ITEM	SYMBOL	MIN.	TYP.	MAX.	UNIT
CLOCK CYCLE TIME	t <sub>cyc</sub>	250	—	—	ns
CLOCK HIGH LEVEL WIDTH	t <sub>cWH</sub>	45	—	—	ns
CLOCK LOW LEVEL WIDTH	t <sub>cWL</sub>	45	—	—	ns
CLOCK RISE TIME	t <sub>r</sub>	—	—	50	ns
CLOCK FALL TIME	t <sub>f</sub>	—	—	50	ns
DATA SETUP TIME	t <sub>DS</sub>	30	—	—	ns
DATA HOLD TIME	t <sub>DH</sub>	30	—	—	ns
CLOCK SETUP TIME	t <sub>sCL</sub>	80	—	—	ns
CLOCK HOLD TIME	t <sub>HCL</sub>	80	—	—	ns
FRAME SETUP TIME	t <sub>SETUP</sub>	30	—	—	ns
FRAME HOLD TIME	t <sub>HOLD</sub>	30	—	—	ns

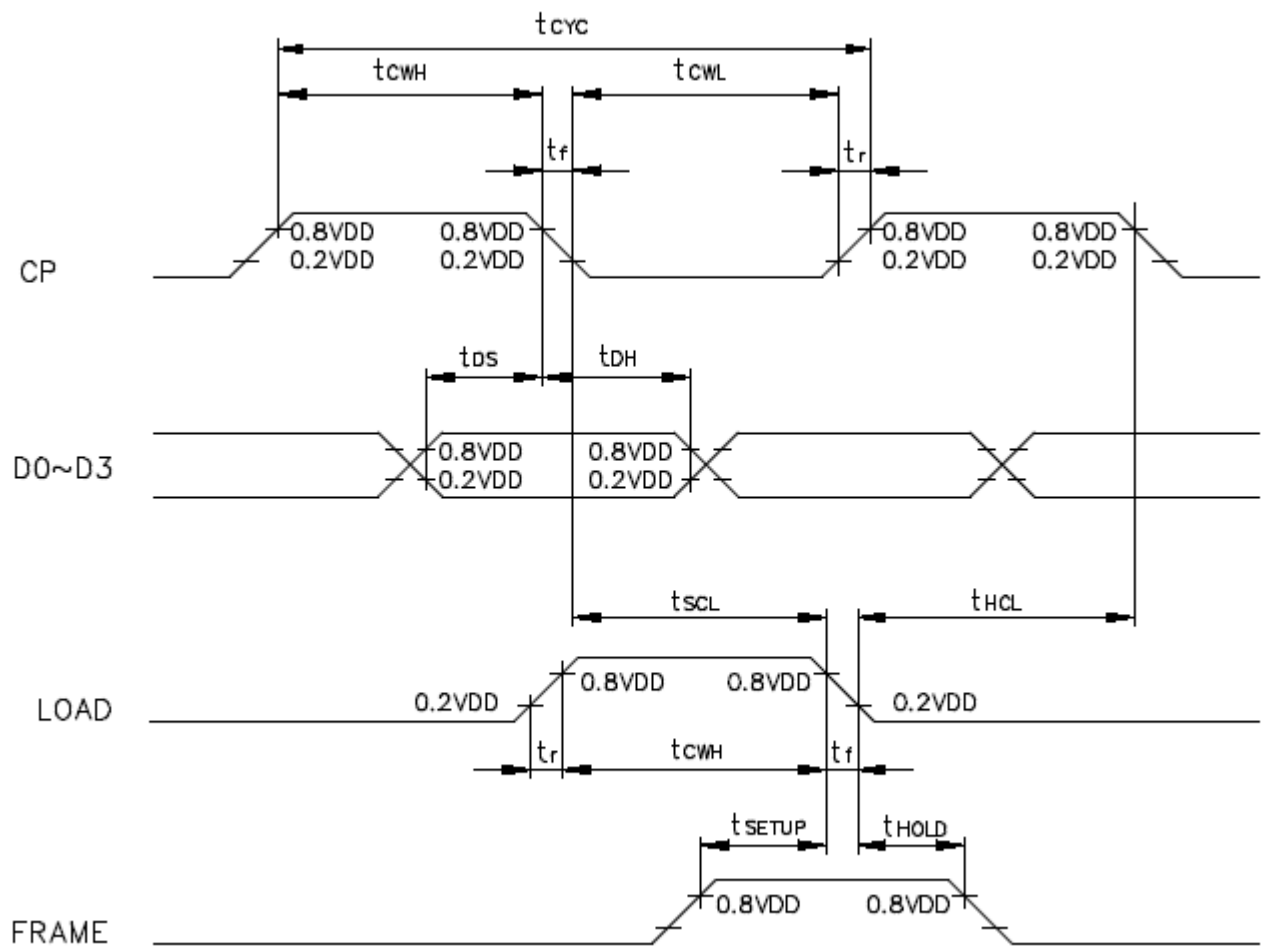

## 10-2 Timing Chart of input signals

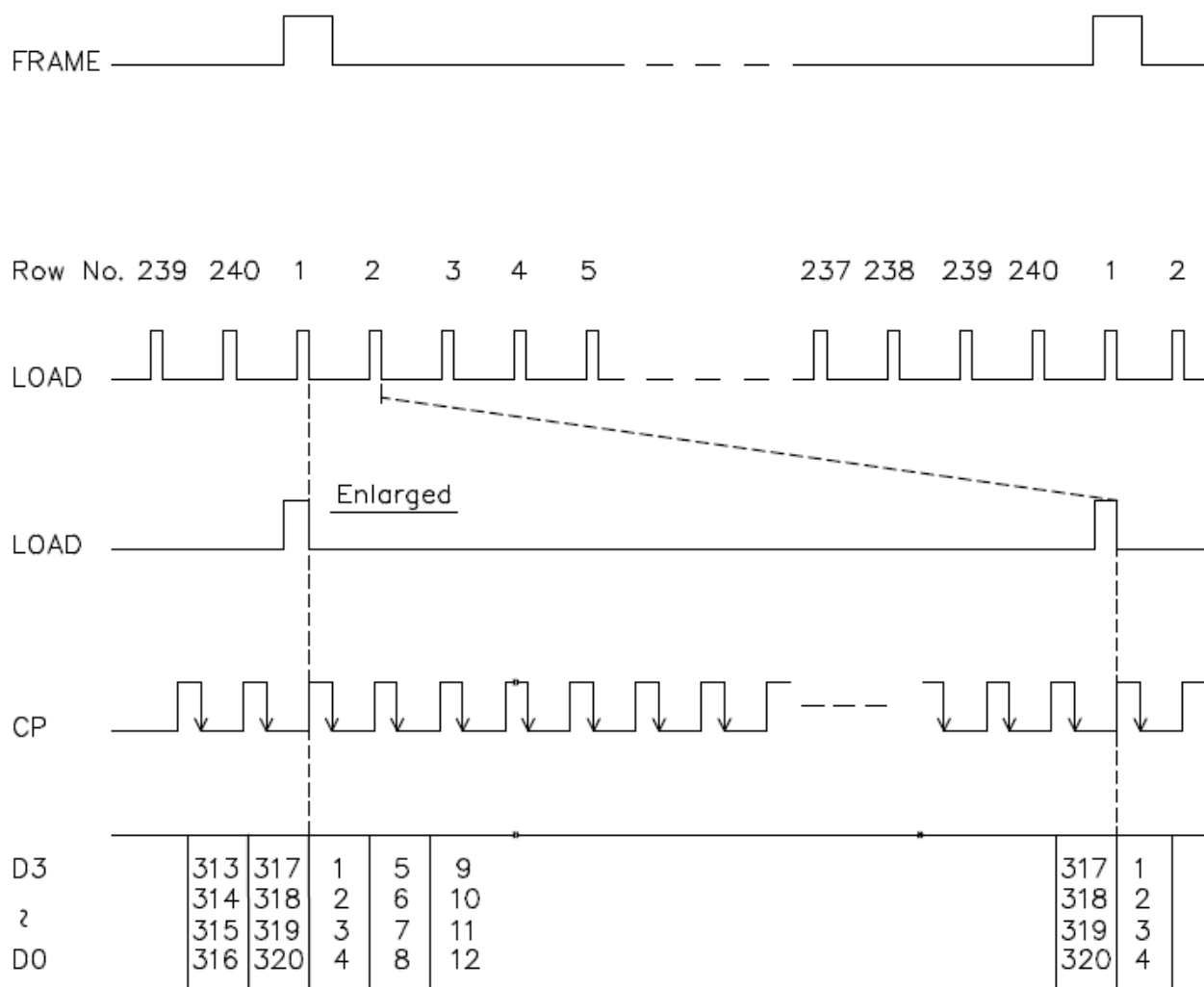

## 10-3 Power ON/OFF Timing

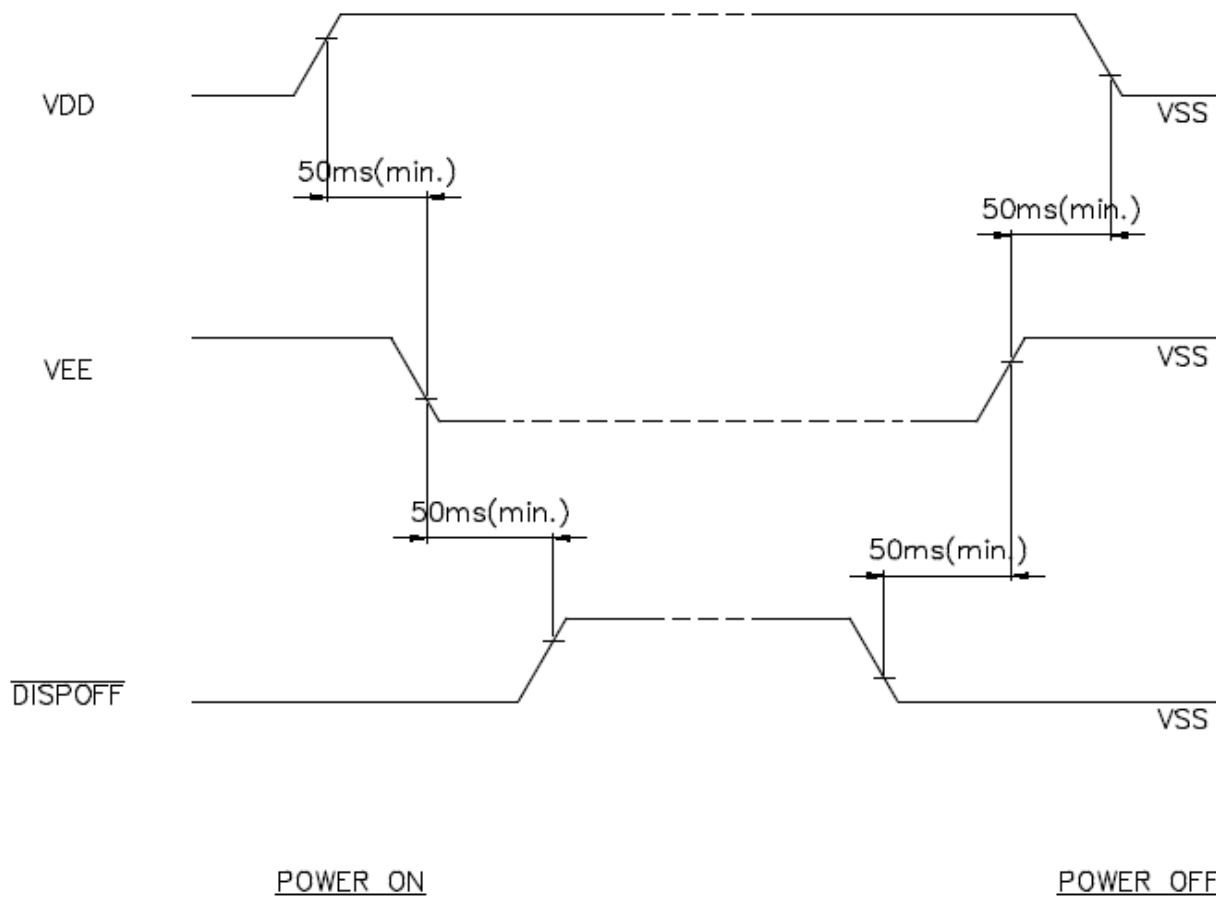

★ The missing pixels may occur when the LCM is driven beyond above power interface timing sequence.

# 10-4 Display pattern

#001	D3	D2	D1	D0	D3		D0	D3	D2	D1	D0
#002	D3	D2	D1	D0	D3		D0	D3	D2	D1	D0
<p>Data Input:  Terminal : Dots (Row) on Display</p> <p>D0 : dot 4, dot 8 ..... dot 316, dot 320  D1 : dot 3, dot 7 ..... dot 315, dot 319  D2 : dot 2, dot 6 ..... dot 314, dot 318  D3 : dot 1, dot 5 ..... dot 313, dot 317</p>											
#239	D3	D2	D1	D0	D3		D0	D3	D2	D1	D0
#240	D3	D2	D1	D0	D3		D0	D3	D2	D1	D0
	d1	d2	d3	d4	d5		d316	d317	d318	d319	d320

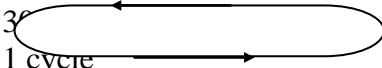

# 11. Reliability

Environmental Test			
Test Item	Content of Test	Test Condition	Note
High Temperature storage	Endurance test applying the high storage temperature for a long time.	80°C 200hrs	2
Low Temperature storage	Endurance test applying the high storage temperature for a long time.	-30°C 200hrs	1,2
High Temperature Operation	Endurance test applying the electric stress (Voltage & Current) and the thermal stress to the element for a long time.	70°C 200hrs	—
Low Temperature Operation	Endurance test applying the electric stress under low temperature for a long time.	-20°C 200hrs	1
High Temperature/ Humidity Operation	The module should be allowed to stand at 60 °C,90%RH max For 96hrs under no-load condition excluding the polarizer, Then taking it out and drying it at normal temperature.	60°C,90%RH 96hrs	1,2
Thermal shock resistance	The sample should be allowed stand the following 10 cycles of operation -20°C    25°C    70°C  	-20°C/70°C 10 cycles	—
Vibration test	Endurance test applying the vibration during transportation and using.	Total fixed amplitude : 1.5mm Vibration Frequency : 10~55Hz One cycle 60 seconds to 3 directions of X,Y,Z for Each 15 minutes	3
Static electricity test	Endurance test applying the electric stress to the terminal.	VS=800V,RS=1.5kΩ CS=100pF 1 time	—

Content of Reliability Test (wide temperature, -20°C~70°C)

Note1: No dew condensation to be observed.

**Note2: The function test shall be conducted after 4 hours storage at the normal Temperature and humidity after remove from the test chamber.**

**Note3: Vibration test will be conducted to the product itself without putting it in a container.**

## **12. Backlight Information**

### **Specification**

<b>PARAMETER</b>	<b>SYMBOL</b>	<b>MIN</b>	<b>TYP</b>	<b>MAX</b>	<b>UNIT</b>	<b>TEST CONDITION</b>
<b>Supply Current</b>	<b>I<sub>LED</sub></b>	<b>108</b>	<b>128</b>	<b>200</b>	<b>mA</b>	<b>V=3.5V</b>
<b>Supply Voltage</b>	<b>V</b>	<b>3.4</b>	<b>3.5</b>	<b>3.6</b>	<b>V</b>	<b>-</b>
<b>Reverse Voltage</b>	<b>V<sub>R</sub></b>	<b>-</b>	<b>-</b>	<b>5</b>	<b>V</b>	<b>-</b>
<b>Luminous Intensity (Without LCD)</b>	<b>I<sub>V</sub></b>	<b>280</b>	<b>-</b>	<b>-</b>	<b>CD/M<sup>2</sup></b>	<b>I<sub>LED</sub>=128mA</b>
<b>Wave Length</b>	<b>X</b>	<b>0.275</b>	<b>0.300</b>	<b>0.325</b>		<b>I<sub>LED</sub>=128mA</b>
	<b>Y</b>	<b>0.265</b>	<b>0.29</b>	<b>0.315</b>		
<b>LED Life Time (For Reference only)</b>	<b>-</b>	<b>-</b>	<b>50K</b>	<b>-</b>	<b>Hr.</b>	<b>I<sub>LED</sub>≤128mA 25°C,50-60%RH, (Note1)</b>
<b>Color</b>	<b>White</b>					

**Note: The LED of B/L is drive by current only ; driving voltage is only for reference**

**To make driving current in safety area (waste current between minimum and maximum).**

**Note 1:50K hours is only an estimate for reference.**

# 13. Inspection specification

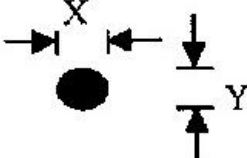
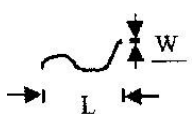
NO	Item	Criterion	AQL												
01	Electrical Testing	1.1 Missing vertical, horizontal segment, segment contrast defect. 1.2 Missing character, dot or icon. 1.3 Display malfunction. 1.4 No function or no display. 1.5 Current consumption exceeds product specifications. 1.6 LCD viewing angle defect. 1.7 Mixed product types. 1.8 Contrast defect.	0.65												
02	Black or white spots on LCD (display only)	2.1 White and black spots on display $\leq 0.25\text{mm}$ , no more than three white or black spots present. 2.2 Densely spaced: No more than two spots or lines within 3mm	2.5												
03	LCD black spots, white spots, contamination (non-display)	3.1 Round type : As following drawing $\Phi = (x + y) / 2$  <table border="1" data-bbox="874 1010 1353 1518"> <thead> <tr> <th>SIZE</th> <th>Acceptable Q TY</th> </tr> </thead> <tbody> <tr> <td><math>\Phi \leq 0.10</math></td> <td>Accept no dense</td> </tr> <tr> <td><math>0.10 &lt; \Phi \leq 0.20</math></td> <td>2</td> </tr> <tr> <td><math>0.20 &lt; \Phi \leq 0.25</math></td> <td>1</td> </tr> <tr> <td><math>0.25 &lt; \Phi</math></td> <td>0</td> </tr> </tbody> </table>	SIZE	Acceptable Q TY	$\Phi \leq 0.10$	Accept no dense	$0.10 < \Phi \leq 0.20$	2	$0.20 < \Phi \leq 0.25$	1	$0.25 < \Phi$	0	2.5		
		SIZE	Acceptable Q TY												
$\Phi \leq 0.10$	Accept no dense														
$0.10 < \Phi \leq 0.20$	2														
$0.20 < \Phi \leq 0.25$	1														
$0.25 < \Phi$	0														
3.2 Line type : (As following drawing)  <table border="1" data-bbox="710 1563 1353 1830"> <thead> <tr> <th>Length</th> <th>Width</th> <th>Acceptable Q TY</th> </tr> </thead> <tbody> <tr> <td>---</td> <td><math>W \leq 0.02</math></td> <td>Accept no dense</td> </tr> <tr> <td><math>L \leq 3.0</math></td> <td><math>0.02 &lt; W \leq 0.03</math></td> <td rowspan="2">2</td> </tr> <tr> <td><math>L \leq 2.5</math></td> <td><math>0.03 &lt; W \leq 0.05</math></td> </tr> <tr> <td>---</td> <td><math>0.05 &lt; W</math></td> <td>As round type</td> </tr> </tbody> </table>	Length	Width	Acceptable Q TY	---	$W \leq 0.02$	Accept no dense	$L \leq 3.0$	$0.02 < W \leq 0.03$	2	$L \leq 2.5$	$0.03 < W \leq 0.05$	---	$0.05 < W$	As round type	2.5
Length	Width	Acceptable Q TY													
---	$W \leq 0.02$	Accept no dense													
$L \leq 3.0$	$0.02 < W \leq 0.03$	2													
$L \leq 2.5$	$0.03 < W \leq 0.05$														
---	$0.05 < W$	As round type													

04	Polarizer bubbles	If bubbles are visible, judge using black spot specifications, not easy to find, must check in specify direction.	Size $\Phi$	Acceptable Q TY	2.5
			$\Phi \leq 0.20$	Accept no dense	
			$0.20 < \Phi \leq 0.50$	3	
			$0.50 < \Phi \leq 1.00$	2	
			$1.00 < \Phi$	0	
			Total Q TY	3	

NO	Item	Criterion	AQL
05	Scratches	Follow NO.3 LCD black spots, white spots, contamination	

Symbols Define:

x: Chip length      y: Chip width      z: Chip thickness  
 k: Seal width      t: Glass thickness      a: LCD side length  
 L: Electrode pad length:

6.1 General glass chip :

6.1.1 Chip on panel surface and crack between panels:

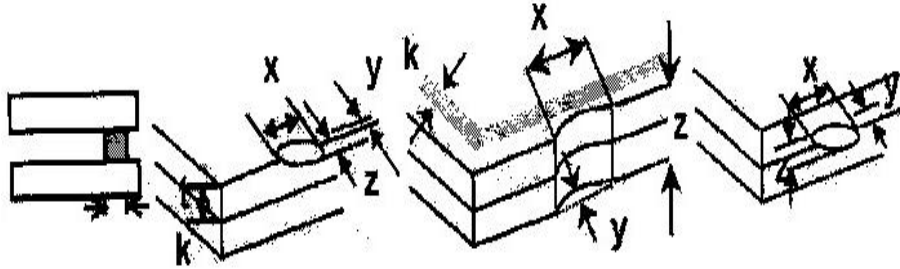

z: Chip thickness	y: Chip width	x: Chip length
$z \leq 1/2t$	Not over viewing area	$x \leq 1/8a$
$1/2t < z \leq 2t$	Not exceed $1/3k$	$x \leq 1/8a$

⊙ If there are 2 or more chips, x is total length of each chip.

6.1.2 Corner crack:

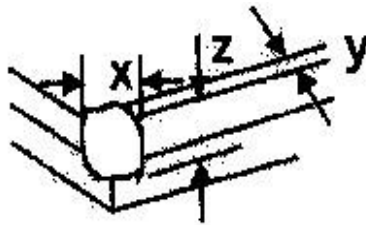

z: Chip thickness	y: Chip width	x: Chip length
$z \leq 1/2t$	Not over viewing area	$x \leq 1/8a$
$1/2t < z \leq 2t$	Not exceed $1/3k$	$x \leq 1/8a$

⊙ If there are 2 or more chips, x is the total length of each chip.

06

Chipped glass

2.5

NO	Item	Criterion	AQL
----	------	-----------	-----

Symbols :

x: Chip length      y: Chip width      z: Chip thickness  
 k: Seal width      t: Glass thickness      a: LCD side length  
 L: Electrode pad length

6.2 Protrusion over terminal :

6.2.1 Chip on electrode pad :

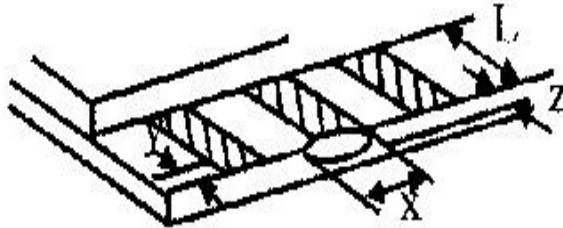

y: Chip width	x: Chip length	z: Chip thickness
$y \leq 0.5\text{mm}$	$x \leq 1/8a$	$0 < z \leq t$

6.2.2 Non-conductive portion:

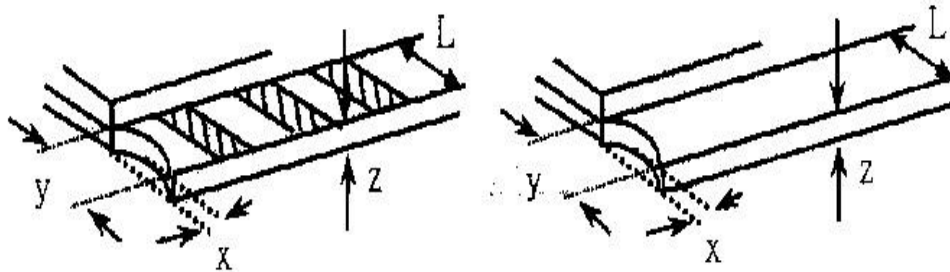

y: Chip width	x: Chip length	z: Chip thickness
$y \leq L$	$x \leq 1/8a$	$0 < z \leq t$

- ⊙ If the chipped area touches the ITO terminal, over 2/3 of the ITO must remain and be inspected according to electrode terminal specifications.
- ⊙ If the product will be heat sealed by the customer, the alignment mark not be damaged.

6.2.3 Substrate protuberance and internal crack.

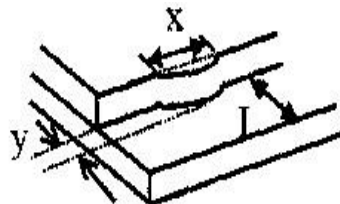

y: width	x: length
$y \leq 1/3L$	$x \leq a$

06

Glass crack

2.5

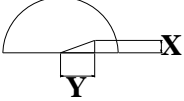
NO	Item	Criterion	AQL
07	Cracked glass	The LCD with extensive crack is not acceptable.	2.5
08	Backlight elements	<p>8.1 Illumination source flickers when lit.</p> <p>8.2 Spots or scratched that appear when lit must be judged. Using LCD spot, lines and contamination standards.</p> <p>8.3 Backlight doesn't light or color wrong.</p>	<p>0.65</p> <p>2.5</p> <p>0.65</p>
09	Bezel	<p>9.1 Bezel may not have rust, be deformed or have fingerprints, stains or other contamination.</p> <p>9.2 Bezel must comply with job specifications.</p>	<p>2.5</p> <p>0.65</p>
10	PCB、COB	<p>10.1 COB seal may not have pinholes larger than 0.2mm or contamination.</p> <p>10.2 COB seal surface may not have pinholes through to the IC.</p> <p>10.3 The height of the COB should not exceed the height indicated in the assembly diagram.</p> <p>10.4 There may not be more than 2mm of sealant outside the seal area on the PCB. And there should be no more than three places.</p> <p>10.5 No oxidation or contamination PCB terminals.</p> <p>10.6 Parts on PCB must be the same as on the production characteristic chart. There should be no wrong parts, missing parts or excess parts.</p> <p>10.7 The jumper on the PCB should conform to the product characteristic chart.</p> <p>10.8 If solder gets on bezel tab pads, LED pad, zebra pad or screw hold pad, make sure it is smoothed down.</p> <p>10.9 The Scraping testing standard for Copper Coating of PCB</p>  <p style="text-align: center;"><math>X * Y \leq 2\text{mm}^2</math></p>	<p>2.5</p> <p>2.5</p> <p>0.65</p> <p>2.5</p> <p>0.65</p> <p>2.5</p> <p>2.5</p> <p>2.5</p> <p>2.5</p>
11	Soldering	11.1 No un-melted solder paste may be present on the PCB.	<p>2.5</p> <p>2.5</p> <p>2.5</p> <p>0.65</p>

		<p>11.2 No cold solder joints, missing solder connections, oxidation or icicle.</p> <p>11.3 No residue or solder balls on PCB.</p> <p>11.4 No short circuits in components on PCB.</p>	
--	--	--	--

NO	Item	Criterion	AQL
12	General appearance	12.1 No oxidation, contamination, curves or, bends on interface Pin (OLB) of TCP.	2.5
		12.2 No cracks on interface pin (OLB) of TCP.	0.65
		12.3 No contamination, solder residue or solder balls on product.	2.5
		12.4 The IC on the TCP may not be damaged, circuits.	2.5
		12.5 The uppermost edge of the protective strip on the interface pin must be present or look as if it cause the interface pin to sever.	0.65
		12.6 The residual rosin or tin oil of soldering (component or chip component) is not burned into brown or black color.	0.65
		12.7 Sealant on top of the ITO circuit has not hardened.	0.65
		12.8 Pin type must match type in specification sheet.	
		12.9 LCD pin loose or missing pins.	
		12.10 Product packaging must the same as specified on packaging specification sheet.	
		12.11 Product dimension and structure must conform to product specification sheet.	



# 14. Material List of Components for RoHs

1. The factory hereby declares that all of or part of products (with the mark “#”in code), including, but not limited to, the LCM, accessories or packages, manufactured and/or delivered to your company (including your subsidiaries and affiliated company) directly or indirectly by our company (including our subsidiaries or affiliated companies) do not intentionally contain any of the substances listed in all applicable EU directives and regulations, including the following substances.

Exhibit A : The Harmful Material List

Material	(Cd)	(Pb)	(Hg)	(Cr6+)	PBBs	PBDEs
Limited Value	100 ppm	1000 ppm	1000 ppm	1000 ppm	1000 ppm	1000 ppm
Above limited value is set up according to RoHS.						

2. Process for RoHS requirement :

(1) Use the Sn/Ag/Cu soldering surface ; the surface of Pb-free solder is rougher than we used before.

(2) Heat-resistance temp. :

Reflow : 250°C, 30 seconds Max. ;

Connector soldering wave or hand soldering : 320°C, 10 seconds max.

(3) Temp. curve of reflow, max. Temp. : 235±5°C ;

Recommended customer’s soldering temp. of connector : 280°C, 3 seconds.



## **SOG32024031-BTV-BWLW**

**Sales signature :** \_\_\_\_\_

**Customer Signature :** \_\_\_\_\_

**Date :**    /    /    \_\_\_\_\_